



# EZ Loader

Operation & Safety Manual



(702) 636-2969  
(800) 497-1704

1415 W. Bonanza Rd. Las Vegas, NV 89106  
[www.XtremeManufacturing.com](http://www.XtremeManufacturing.com)  
May 2020



<b>Introduction . . . . .</b>	<b>2</b>	Unloading Operation . . . . .	32
General . . . . .	2	Retract Ramp . . . . .	33
Replacement Manuals . . . . .	2	<b>Preventive Maintenance . . . . .</b>	<b>35</b>
Orientation . . . . .	2	Weekly Maintenance . . . . .	35
Vehicle Compliance . . . . .	2	Semi-Annual Maintenance . . . . .	35
Dealer Responsibility . . . . .	3	Replacing Oil and Filter . . . . .	35
Delivery Report . . . . .	3		
Model/Serial Numbers . . . . .	3		
Nomenclature . . . . .	4		
<b>Safety . . . . .</b>	<b>5</b>		
Safety Disclaimer . . . . .	5		
Signal Words . . . . .	5		
Safety Symbols . . . . .	5		
Employer Responsibility . . . . .	8		
Operator Responsibility . . . . .	8		
Operator Qualification . . . . .	9		
Modifications . . . . .	9		
Before Starting Vehicle . . . . .	10		
Operation Safety . . . . .	11		
Load Safety . . . . .	11		
Vehicle Maintenance . . . . .	11		
Safety Equipment . . . . .	12		
Fire Extinguisher . . . . .	12		
First Aid Kit . . . . .	14		
Wheel Chocks . . . . .	14		
Chock Selection . . . . .	14		
Chock Performance . . . . .	15		
Using Chocks . . . . .	15		
<b>Labels . . . . .</b>	<b>16</b>		
Replacement Labels . . . . .	16		
Label Legend . . . . .	16		
12M Labels . . . . .	17		
18M Labels . . . . .	18		
24M Labels . . . . .	19		
<b>Features . . . . .</b>	<b>20</b>		
Standard Equipment . . . . .	20		
Optional Equipment . . . . .	20		
Specifications . . . . .	21		
<b>Pre-Operation Inspection . . . . .</b>	<b>22</b>		
Pre-Operation Inspection Checklist . . . . .	22		
<b>Controls . . . . .</b>	<b>23</b>		
Flip Tail Control . . . . .	23		
Dove Tail Control . . . . .	23		
Winch Control . . . . .	24		
Power Take Off (PTO) . . . . .	25		
<b>Operation . . . . .</b>	<b>26</b>		
Winch Operation . . . . .	26		
Extend Ramp . . . . .	28		
Loading Operation . . . . .	30		

## ⚠ WARNING

Improper operation of the EZ Loader can cause injury or death.

**BEFORE** operating the EZ Loader, the operator must do the following:

- Read all Operator Manuals supplied with the EZ Loader completely and carefully, understand all safety instructions, operation of controls, and safety equipment.
- Read all safety labels on the vehicle and truck bed.
- Learn and practice safe use of EZ Loader operator controls in a safe, clear area.

You are responsible for observing all applicable Federal, State, and Local Laws and Regulations and for following the manufacturer's instructions for operation and maintenance of the EZ Loader.

This information is provided for your benefit and you must comply with all **DANGER**, **WARNING**, and **CAUTION** notices.

## General

The EZ Loader is designed to streamline equipment delivery operations for any industry. The all-steel construction makes the EZ Loader an extremely durable and valuable resource for transporting vehicles and equipment.

This Operator Manual provides important information needed to safely operate the EZ Loader. This manual should be kept with all other vehicle operator manuals and considered a permanent part of the EZ Loader.

## Replacement Manuals

Replacement manuals for the EZ Loader can be obtained by contacting:

**Xtreme Manufacturing**  
Phone: (800) 497-1704

## Orientation

Right side, left side, front, and rear are directional references given from the operator's seat while facing in a forward direction.

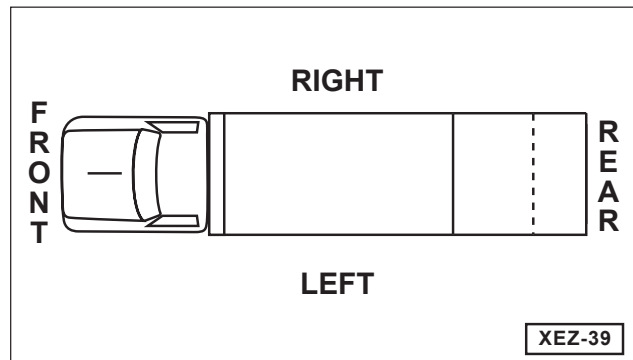

Figure 1-1. Vehicle Direction Orientation.

## Vehicle Compliance

### ⚠ WARNING

Federal law (49 CFR part 571) requires that the Final Stage Manufacturer of a vehicle certify that the vehicle complies with all applicable federal regulations. Any modifications performed on the vehicle prior to the final stage are also considered intermediate stage manufacturing and must be certified as to compliance. The installer of the EZ Loader and its components is considered one of the manufacturers of this vehicle. As such a manufacturer, the installer is responsible for compliance with all applicable federal and state regulations, and is required to certify that the vehicle is in compliance.



**Dealer Responsibility**

Your EZ Loader dealer is an important source of information and assistance and is responsible for:

- Providing a complete delivery report within the specified time frame required to comply with the manufacturer’s warranty.
- Explaining the capabilities and restrictions of the EZ Loader’s applications.
- Demonstrating the safe operation of the EZ Loader according to the instructional materials, which should also be made available to the operator.
- Identifying any unsafe modifications made to the EZ Loader.

For any questions regarding safety, operation, or capacity of the truck, truck bed, and EZ Loader and for specific information related to parts and service procedures, contact:

**Xtreme Manufacturing**  
**Phone: (800) 497-1704**  
**Fax: (702) 367-4134**

**NOTE:** Some older models of the EZ Loader may require different parts and service procedures.

**Delivery Report**

Your EZ Loader dealer will review the delivery report with you.

The delivery report contains these items:

- Affidavit of Purchaser
- Affidavit of None Operation
- Weight Certificate
- Title or Manufacturers Statement of Origin (MSO)
- Odometer Statement
- Operation and Maintenance Manual(s)

For easy reference record the vehicle identification number, model, and serial number in the space provided.

<b>Vehicle Identification Number (VIN)</b>	
<b>Model Number</b>	
<b>Serial Number</b>	

**Model/Serial Numbers**

Have the model number, serial number, and vehicle identification number (VIN) available when contacting Xtreme Manufacturing for parts or service information.

The model/serial number plate is located on the front right, lower bulkhead crossmember.



Figure 1-2. EZ Loader Model/Serial Number Plate.

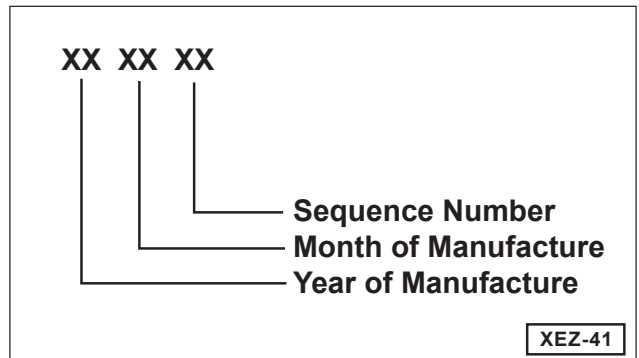

Figure 1-3. Explanation Of Serial Number.

The vehicle identification number will be located behind the driver’s seat OR in the driver’s door jamb. The VIN number will be included on the yellow “Complete Vehicle” tag.



Figure 1-4. Vehicle Identification Number (VIN).

Nomenclature

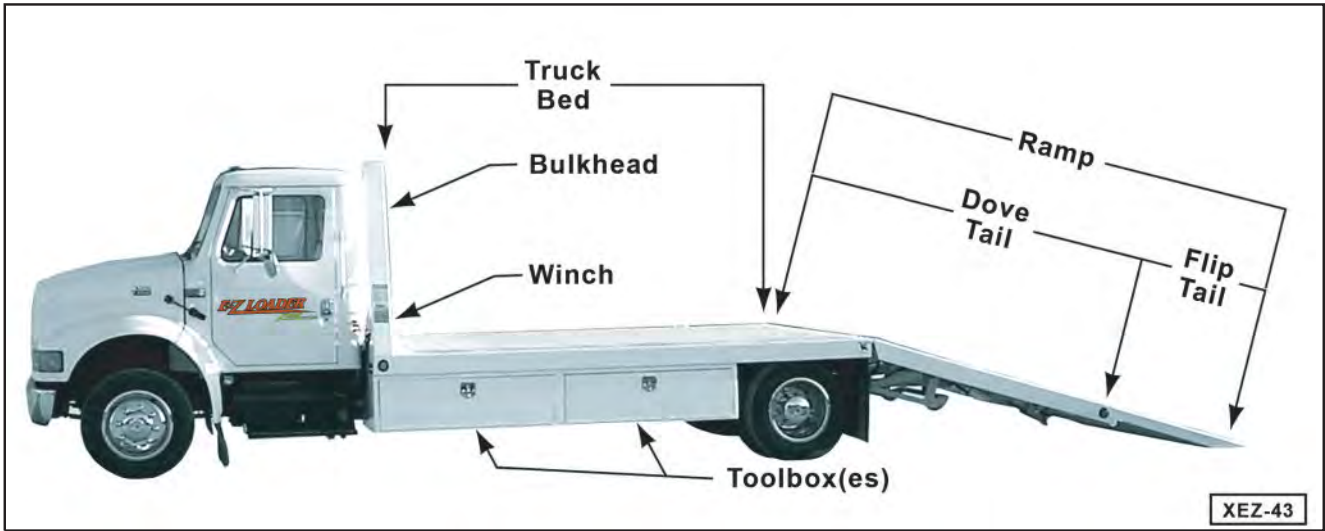

Figure 1-5. EZ Loader Nomenclature.

## Safety Disclaimer



Figure 2-1. Think Safety.

Xtreme Manufacturing reserves the right to make technical changes for product improvement. This manual may contain illustrations and photographs, for demonstration purposes, which slightly deviate from the actual product.

Safety information provided in this manual is a basic guide and an attempt to prevent accidents. Xtreme Manufacturing cannot anticipate every circumstance that might involve a potential hazard. Warnings in this manual and on the vehicle are NOT all-inclusive.

You are responsible for safe operation of this equipment. You must satisfy yourself that the techniques, operating procedures, work methods, and tools you use are safe; especially those NOT SPECIFICALLY mentioned by Xtreme Manufacturing.

The safety of everyone around this equipment depends significantly on your knowledge and understanding of correct and safe operating practices and procedures. You can help prevent accidents by remaining alert and recognizing potentially hazardous situations.

Follow State and Federal health and safety rules and/or local regulations for operating and maintaining this equipment.

- This manual does not replace any laws and regulations.
- The operator and the equipment are required to comply with all applicable laws and regulations.

## Signal Words

Signal words are the word or words that call attention to the safety sign and designate a degree or level of hazard seriousness. The signal words used in this manual are DANGER, WARNING, and CAUTION.

### ⚠ DANGER

DANGER indicates an imminently hazardous situation which, if not avoided, will result in death or serious injury.

### ⚠ WARNING

WARNING indicates a potentially hazardous situation which, if not avoided, could result in death or serious injury.

### ⚠ CAUTION

CAUTION indicates a potentially hazardous situation which, if not avoided, could result in minor or moderate injury.

### CAUTION

CAUTION used without the safety alert symbol indicates a potentially hazardous situation which, if not avoided, may result in property damage.

## Safety Symbols

### ⚠ WARNING

Safety symbols are provided to remind the operator of hazardous situations. Xtreme Manufacturing provides symbols in an attempt to inform all operators, regardless of reading and language skills, of as many potential hazards as possible. These symbols cover many, but not all, potential dangers and hazards associated with operating the EZ Loader.

Make safety a high priority while operating the vehicle. Learn and follow all safety messages in this manual and on vehicle labels to prevent equipment damage, injury, or death.



General Safety Alert Symbol



Read Operator Manual Before Operating This Vehicle



Read Maintenance Manual Before Working On This Vehicle



Perform Operator Inspection Before Starting This Vehicle



Read Material Safety Data Sheets (MSDS) For Chemicals And Fluids



Know First Aid Instructions And/Or Locations On Worksite



DO NOT Operate If Using Alcohol, Drugs, Or Medications



Personal Protective Equipment Hardhat



Personal Protective Equipment Gloves



Personal Protective Equipment Safety Shoes



Personal Protective Equipment Safety Glasses



Personal Protective Equipment Ear Protectors



Lead Acid Batteries Create Explosive Gases



No Smoking Keep Lit Cigarettes Away



Keep Flames And Ignition Sources Away



Warning! Hydraulic Oil Under Pressure

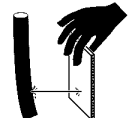

Use A Board Or Cardboard To Check Hydraulic Leaks. DO NOT Use Your Hand!

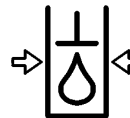

Hydraulic System Under Pressure



Hot Oil! DO NOT Open Unless Cap Is Cool To Touch



Make Sure All Safety Decals Are Attached And Legible



Replace Worn And Illegible Safety Decals And Labels



Fasten Seat Belt



DO NOT Allow Riders On Vehicle Frame Or Fenders



DO NOT Allow Riders On The Operator Cab



Set Parking Brake To ON Engage Parking Brake



Set Parking Brake To OFF Disengage Parking Brake





**Pinch Points  
Hands**



**Crush Hazard  
Be Careful Not  
To Place Feet  
Under Ramp**



**Chock Wheels  
For Loading  
And Unloading  
Procedures**



**Warning!  
Vehicle Roll  
Away Can  
Cause Death Or  
Serious Injury**



**Use Three (3)  
Point Contact  
Mounting And  
Dismounting  
The Vehicle**



**DO NOT  
Jump While  
Dismounting  
The Vehicle**



**Tripping Hazard  
Remove Loose  
Objects From  
Work Area And  
Truck Bed**



**Slipping Hazard  
Clean Spilled Or  
Leaking Fluids  
Immediately**

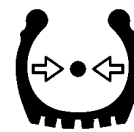

**Maintain Proper  
Air Pressure  
(Pneumatic  
Tires Only)**

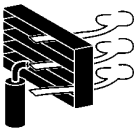

**Have Adequate  
Ventilation If  
Operating This  
Vehicle In An  
Enclosed Space**



**Winch  
Keep At Least  
Five (5) Wraps  
On Winch Drum**



**DO NOT Use  
Winch If Wire  
Rope Is Frayed  
Or Kinked**



**Use Proper  
Techniques To  
Lift Or Move  
Items To Avoid  
Back Injury**



**Personal  
Protective  
Equipment  
Face Shield**



**Hot Surface!  
Keep Hands  
Away**



**Warning!  
Fire Hazard**



**Fire  
Extinguisher**

## Employer Responsibility

Under OSHA rules, employers are required to train workers about hazards related to operating and maintaining the EZ Loader.

Operator trainees must remain under constant observation and supervision of an experienced operator.

An untrained operator can unknowingly create a dangerous situation which can result in the injury or death of the operator and others.

Only allow trained, qualified, and authorized personnel to operate the EZ Loader without supervision.

Safety and training information can be obtained through these publications, organizations, and/or other appropriate sources:

- Code of Federal Regulations (29 CFR)
- Occupational Safety and Health Administration (OSHA)
- National Institute for Occupational Health and Safety (NIOSH)
- American National Standards Institute (ANSI)
- Association of Equipment Manufacturers (AEM)
- American Society of Mechanical Engineers (ASME) (including ASME B30.7, B30.9)
- National Fire Protection Association, Inc. (NFPA Standard #10)
- Department of Transportation (DOT)
- National Safety Council, Accident Prevention Manual for Industrial Operations
- Federal Motor Carriers Safety Regulations (FMCSR 392.7)

Always consult Material Safety Data Sheets (MSDS) for chemical hazards and first aid instructions for any oil or lubricant being used. MSDS should be available from the manufacturer or supplier of the fluid.

## Operator Responsibility

### WARNING

The EZ Loader is potentially dangerous if proper safety procedures are not followed. Workers who operate, maintain, or work near the EZ Loader can be at risk of roll over and run over incidents. Workers can be crushed or caught by the EZ Loader or its parts if it is not operated or maintained properly.



Read all Operator Manuals before operating the EZ Loader. Only operate the vehicle if you understand the safety instructions and warnings in all applicable manuals and technical publications. Follow all safety instructions, labels, and all State and Federal health and safety laws and/or local regulations.

You must have the required training, skills, and tools to perform installation, operation, maintenance, or repair procedures properly and safely. Make sure the EZ Loader will not be damaged or made unsafe by any procedures you choose.

Make sure the EZ Loader meets all local, state, and federal regulations; including, but not limited to those required for bumpers, lighting, and reflectors.

**DO NOT** allow untrained personnel or children to play around or operate the EZ Loader.

You are responsible for safe operation of the winch. Exercise caution, use common sense, and be familiar with safe rigging techniques. Refer to applicable industry standards for rigging techniques, including ASME B30.9 for rigging information, American National Standards Institute, 1430 Broadway, New York, NY 10018.

**DO NOT** use this equipment for any other purpose than what it was designed for and refuse to operate any equipment that shows signs of abuse, damage, fails to operate freely and smoothly, or has “DO NOT OPERATE” tags attached to it.

## Operator Qualifications

### DANGER



Operators must be properly trained, qualified, and authorized to operate this vehicle. Know the location, learn the specific purpose, and demonstrate safe and proper use of all controls, instruments, indicator lights, and safety and instruction labels. Safety is your responsibility.

Trained and qualified operators will:

- be in good physical and mental condition, with appropriate reflexes, reaction time, vision, depth perception, and hearing.
- possess a valid, current driver's license as required for the worksite; plus those required by applicable State, Federal, and/or local laws.
- be properly instructed on how to operate the vehicle, EZ Loader, winch, and other equipment from having worked under experienced supervision.
- have operated the EZ Loader and the winch.
- have read the installation, operation, maintenance, and parts manual(s).
- have read and understand all applicable warnings, cautions, and appropriate safety regulations.
- have had their employer explain to them the hazards of operating the EZ Loader at each particular job site.
- have received training regarding the hauling and tie-down of vehicles and/or equipment being transported.
- be familiar with hazards of operating in dangerous locations or conditions; such as:
  - where power lines are located
  - irregular ground contour exists
  - locations where mud, rain, or other severe weather conditions can interfere with normal and otherwise safe operations

## Modifications

### WARNING



Modifying the truck or EZ Loader can affect vehicle capacity and/or stability. **DO NOT** make modifications to the truck or EZ Loader without prior written approval from the manufacturer. Where such authorization is granted, capacity, operation, and maintenance instruction plates, tags, or labels shall be changed accordingly.

- Unauthorized modifications or alterations will VOID the warranty.
- **DO NOT** modify, disable, or bypass any safety devices.

### WARNING

#### California Proposition 65

Engine exhaust from this product contains chemicals known to the State of California to cause cancer, birth defects, and other reproductive harm.

**⚠ WARNING**



Wear appropriate protective clothing. Personal protective equipment can include, but is not limited to hardhat, gloves, footwear, safety glasses or goggles, and hearing protection.

Make sure clothing is snug and properly belted. **DO NOT** wear loose clothing, jewelry, watches, or anything that can catch on vehicle controls, moving parts, etc.

**Before Starting Vehicle**

**⚠ WARNING**



Keep a complete set of Operator Manuals with the vehicle at all times. Contact Xtreme Manufacturing for any replacement manuals.



Clearly define responsibilities and procedures for operating the truck and EZ Loader. **DO NOT** proceed until you seek expert assistance from a qualified person if any doubt or question arises about the correct or safe methods for operating the vehicle.



To avoid injury or death, carefully read and understand all instructions before operating the vehicle. **DO NOT** operate, modify, repair, or maintain the truck or EZ Loader unless you read and understand the instructions and warnings in this and all other applicable manuals and technical publications. Follow all State and Federal health and safety laws and/or local regulations.



Consult Material Safety Data Sheets (MSDS) for chemical hazards and first aid instructions. MSDS should be available from the manufacturer or supplier of the fluid.

**⚠ WARNING**



Perform a daily visual inspection and have necessary repairs made **BEFORE** operating the EZ Loader. Perform a daily pre-trip inspection in accordance with the Federal Motor Carriers Safety Regulations (FMCSR 392.7). **DO NOT** perform the visual inspection with the truck engine running or hot. Contact with moving or heated parts can cause injury or death.



Perform functional tests in an open area. Inspections and functional tests may require assistance. Keep the assistant visible and a safe distance from the truck to prevent injury or death.



Become familiar with all safety and hazard labels, regulations, and procedures. Make sure all safety and hazard labels are attached to the EZ Loader and/or truck and are legible at all times to ensure the greatest level of safety. Safety labels provide a vital role in helping to reduce injuries and/or possibly even death. Remember, it is the users responsibility to maintain these labels. For a complete part number list, label placement, and illustrations of the labels used on the EZ Loader, refer to the Labels section in this manual.



A brief description of controls is provided as a convenience for the operator. These descriptions **DO NOT** provide complete operation instructions. Read and understand the entire manual to prevent equipment damage, injury, or death.



Keep fingers and feet away from moving parts or pinch points to prevent pinching or crushing.



**Operation Safety**

**⚠ WARNING**



Operators must be properly trained and qualified to operate this specific vehicle. Know the location, learn the specific purpose, and demonstrate safe and proper use of all controls, instruments, indicator lights, and safety and instruction labels. Safety is your responsibility.

**⚠ DANGER**

- Injury or death by electrocution can result from contact with or inadequate clearance with energized power lines or apparatus.
- NEVER operate the vehicle in an area where active overhead power lines, overhead or underground cables, or other power sources exist.
- Contact the appropriate power or utility company to de-energize power lines or take other suitable precautions.



Keep the vehicle, attachments, and loads a safe distance from electrical power lines.

- Remain at least 10 feet (3 meters), plus an additional 0.4 inches (10 millimeters) for each 1,000 Volts over 50,000 Volts, from active power lines and other power sources.
- Worksite operating directives and/or local or state codes might require a greater distance.

**⚠ WARNING**



NEVER allow passengers to ride on the vehicle. DO NOT allow riders on the frame or operator cab.



Engine fuel is flammable and can cause a fire or explosion. DO NOT smoke while refueling and keep sparks and open flames away from the vehicle.

**⚠ CAUTION**



Contact with hot surfaces and the exhaust pipe after the vehicle has been operated can result in serious personal injury.

**Load Safety**

**⚠ WARNING**

The load can affect the driving and handling characteristics of the truck. Follow industry standards to safely and securely load the truck. Evenly distribute the load weight on the truck bed and make sure the load height is within legal requirements.

DO NOT exceed the manufacturer's maximum rated capacity on the truck bed, dove tail, ramp, or axles. Overloading can result in equipment damage, injury, or death.

Capacity rating for bed only, vehicle capacity rating dependent on final configuration of chassis, options installed, road regulation, and drivetrain specifications.

**Vehicle Maintenance**

**⚠ WARNING**

Follow the manufacturer's instructions for proper maintenance to make sure the vehicle continues to meet manufacturer's specifications.

- DO NOT operate the vehicle and attachments if they require repairs.
- Make sure basic maintenance is completed and service problems are corrected.
- Injury or death can result from operating a vehicle before all repairs have been made and all proper maintenance is completed.

**⚠ WARNING**

**California Proposition 65**



Battery posts, terminals, and related accessories contain lead and lead compounds, chemicals known to the State of California to cause cancer, birth defects, or other reproductive harm. Wash hands after handling these items.

**Safety Equipment**

**⚠ WARNING**

Safety instructions are provided to prevent accidents whenever possible. If an accident or fire occurs, react quickly with the tools and skills available. Know how to use the fire extinguisher and first aid kit and where to get assistance.

**Fire Extinguisher**



Figure 2-2. Fire Extinguisher.

**⚠ DANGER**



If you suspect a vehicle fire, immediately turn the engine OFF. Make sure the fire extinguisher is rated to fight a vehicle fire.

If you see smoke, but no visible flames, escaping from under the vehicle’s hood; use extreme caution when checking the source. Be careful lifting the hood of the vehicle. Flames may flare up when you open the hood and can cause severe injury or death.

If you see flames escaping from under the vehicle’s hood then the fire is too large to fight and you should evacuate everyone a safe distance from the vehicle.

DO NOT attempt to open the hood or fight the fire. Trying to fight a large fire can result in injury or death.

**IMMEDIATELY CALL THE FIRE DEPARTMENT FOR HELP.**

**⚠ WARNING**

If installing or replacing a quick-release bracket for the fire extinguisher, mount the bracket according to the user manual.

DO NOT use sheet metal or wood screws, because vehicle vibrations may loosen the screws.

DO NOT make holes in the vehicle structure without checking the opposite side. Creating holes in the vehicle structure can cause severe damage to electrical lines, gasoline lines or tanks, or other vehicle systems.

DO NOT break the plastic loop holding the safety pin in place. The plastic loop prevents accidental discharge of the fire extinguisher. Break the loop only in an emergency before using the fire extinguisher.

DO NOT check the pressure or test the fire extinguisher by spraying it, even briefly. Once used it will gradually lose pressure and will not be fully charged for use in an emergency.

DO NOT puncture or burn any fire extinguisher. Never locate a fire extinguisher close to an engine or other heat source. Never expose a fire extinguisher to temperatures over 150° F (66° C), even if it is fully discharged. A fire extinguisher is pressurized and can rupture or explode.

Some fire extinguishers contain a dry powder extinguishing agent. The powder is not toxic, but can irritate skin. Avoid breathing the powder and always ventilate the area after use.

DO NOT try to service or repair this fire extinguisher under any circumstances. DO NOT try to remove the nozzle or valve assembly. This is a pressurized device that can cause serious injury if tampered with.

Failure to install or handle a fire extinguisher correctly can result in damage, injury, or death.

A vehicle fire extinguisher is designed to fight small fires that have just started and are small enough to fight safely. Make sure your extinguisher can safely and effectively be used on the combustible materials you use it on.

Always use extreme caution when fighting any fire.

**⚠ WARNING**

Fight a fire only where there is a clear escape path that allows you to get away safely if the fire gets worse.

Always remain far enough away from the fire and make sure nothing is between you and an escape route.

If you get too close to a fire, you risk getting burned or hit by splattering material like oil or grease.

**DO NOT** try to fight a fire that is too hot or smoky to get within 6 feet (2 meters) of. A vehicle fire extinguisher is not designed to fight large fires that are burning out of control. Warn everyone, evacuate the area, and call the Fire Department a safe distance from the vehicle.

Trying to fight a large fire yourself can result in injury or death.

Fight the fire from an upwind direction with your back to any strong air current. Fighting a fire with the wind blowing towards you can result in injury or death.

Avoid breathing smoke and heated fumes and stay low, if necessary. Burning materials will release toxic fumes which can result in injury or death.

If a vehicle has started on fire and the fire has been extinguished, **DO NOT** start the vehicle or plug in any electrical accessories (cellular phone, CD player, etc.) until the vehicle has been thoroughly and completely cleaned. Failure to remove the powder from electrical equipment can create a hazardous situation. If the powder gets wet, it can conduct electricity. This may worsen an electrical leakage problem, impair the equipment's insulation, or create an electrical shock hazard.

Using a dry chemical extinguisher on wet electrical equipment can be hazardous, because it can conduct electricity if the powder gets wet, resulting in electrocution.

Read the fire extinguisher's user manual and label carefully and keep it with the vehicle. Review the user manual regularly because it contains important information about operating the fire extinguisher and in an emergency you will not have time to read the instructions.

Fire extinguishers are classified by fire type. The fire extinguisher rating system (A, B, and C) defines the burning materials a fire extinguisher is designed to fight.

- **Class A:** This fire extinguisher is suitable for fighting small fires involving wood, paper, cloth, rubber, and some plastics.
- **Class B:** This fire extinguisher is suitable for fighting small fires involving grease, gasoline, oil, kerosene, and other flammable liquids.
- **Class C:** This fire extinguisher is suitable for fighting small fires involving "live" electrical equipment.

The numbers in front of the rating indicate the size of fire the fire extinguisher is useful for.

**NOTE:** Make sure the extinguisher is rated to fight the type of fire most likely to occur in or around the vehicle. Make sure you understand which fire extinguisher to use on each class of fire. Using the wrong type of fire extinguisher can do more harm than good.

**NOTE:** Additional information on fire extinguishers can be obtained from the National Fire Protection Association Standard Number 10, "Portable Fire Extinguishers," available from the National Fire Protection Association, Inc., Batterymarch Park, Quincy, MA 02169, USA.

### First Aid Kit



Figure 2-3. First Aid Kit.

An emergency first aid kit should be readily available within the workplace for the treatment of minor workplace injuries. Make sure an appropriate first aid kit remains with the vehicle and is fully stocked. Make sure the first aid kit is restocked immediately after each use to comply with applicable regulations, including Occupational Safety and Health Administration (OSHA) regulation 1910.151b and American National Standards Institute (ANSI) standard Z308.1.

### Wheel Chocks

#### ⚠ WARNING



Chock tires to stop vehicle from rolling. Failure to chock tires or improper use of chocks can cause the vehicle to roll, resulting

in injury or death.

Improper positioning of chocks will decrease their effectiveness and improper chocking materials can become explosive projectiles or cause tire damage, punctures, or exploding.

When chocks are used properly they are effective holding devices that will prevent a vehicle from rolling and becoming dangerous to the operator or other people in the area.

Use chocks to secure a vehicle

- that will be left unattended.
- that is disabled.
- that is in the shop for maintenance.
- during loading and unloading procedures.

**NOTE:** OSHA requires that a vehicle's brakes be set and chocks placed under the wheels to prevent the vehicle from rolling while it is loaded or unloaded.

### Chock Selection

1. Select chocks according to the type and size of the vehicle.
2. Select brightly colored, highly visible chocks.
3. Test all chocks to make sure they meet safety and durability requirements and to determine the best chock for your particular applications.

**NOTE:** If possible, test the chocks in a variety of conditions to determine the best chock for the type of vehicle and applications they will be used with.

4. Make sure chocks are designed to withstand being driven over without becoming an exploding projectile and without causing tire damage, punctures, or exploding.



## Chock Performance

Many factors can affect the performance of chocks, including:

- gross vehicle weight
- road conditions (i.e. firm, soft, wet, dry, icy)
- tire size
- tire pressure
- type of tire

**NOTE:** Radial tires are designed to deflect more than bias-ply tires to provide a smooth, comfortable ride, however, this factor allows radial tires to wrap around a chock and makes the chock less effective.

## Using Chocks

1. Make sure the vehicle is parked on a firm, level surface.
2. Apply the parking brake and test how well it is holding before placing wheel chocks.
3. Always use chocks in pairs.
4. Chock the vehicle's wheels in the direction of the grade.
  - a. Position chocks downhill, below the vehicle's center of gravity.
  - b. Chock in front of the wheels if the vehicle is facing down a grade.
  - c. Chock behind the wheels if the vehicle is facing up a grade.
  - d. Chock in front of and behind the wheels if the vehicle is on a level surface or if the direction of the grade is undetermined.
5. Center chocks square and snug against the tread of each tire.
6. DO NOT drive over chocks.
7. Inspect chocks periodically for cracking, chipping, or other signs of damage.

**NOTE:** Improper positioning of wheel chocks will decrease their effectiveness.

### Replacement Labels

Replacement labels can be obtained by contacting Xtreme Manufacturing at (800) 497-1704. Please have the appropriate label number available when you call.

### Label Legend

#### Left Side View

### ⚠ WARNING



Become familiar with all safety and hazard labels, regulations, and procedures. Make sure all safety and hazard labels are attached to the EZ Loader and/or truck and are legible at all times to ensure the greatest level of safety. Safety labels provide a vital role in helping to reduce injuries and/or possibly even death. Remember, it is the users responsibility to maintain these labels.



Figure 3-1. Label Legend For 12M, 18M, and 24M Models.

#### Right Side View



Figure 3-2. Label Legend For 12M, 18M, and 24M Models.

12M Labels

Table 1.  
12M Labels

Item	Qty.	Part No.	Description
1	2	XEZ-12-8C-03	Dove Tail Capacity
2	4	XEZ-12-12C-03	Truck Bed Capacity
3	4	XEZ-PP-03	Danger, Pinch Point
4	1	XEZ-CON-03	Controls
5	1	XEZ-12-CAU-03	Caution

1. XEZ-12-8C-03



2. XEZ-12-12C-03

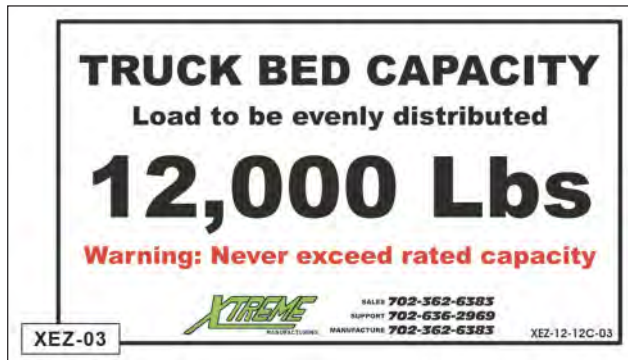

3. XEZ-PP-03



4. XEZ-CON-03



5. XEZ-12-CAU-03

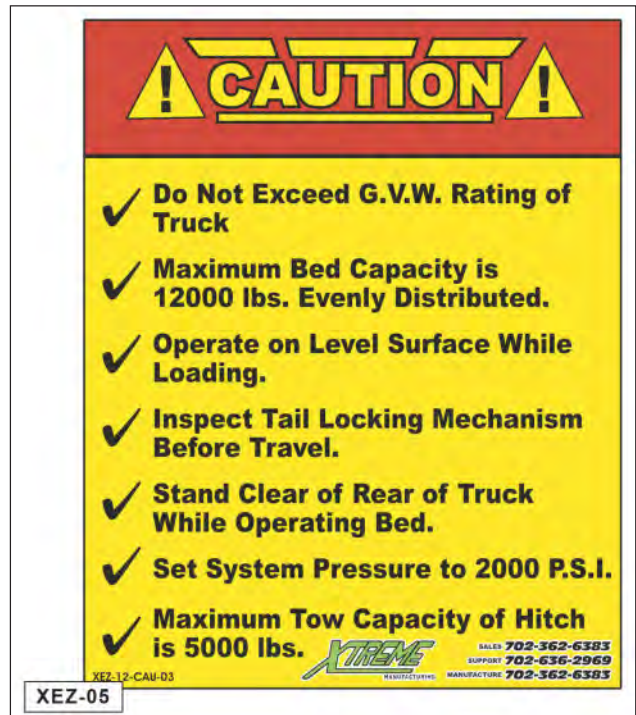



18M Labels

Table 2.  
18M Labels

Item	Qty.	Part No.	Description
1	2	XEZ-18-10C-03	Dove Tail Capacity
2	4	XEZ-18-18C-03	Truck Bed Capacity
3	4	XEZ-PP-03	Danger, Pinch Point
4	1	XEZ-CON-03	Controls
5	1	XEZ-18-CAU-03	Caution

1. XEZ-18-10C-03



2. XEZ-18-18C-03



3. XEZ-PP-03



4. XEZ-CON-03



5. XEZ-18-CAU-03

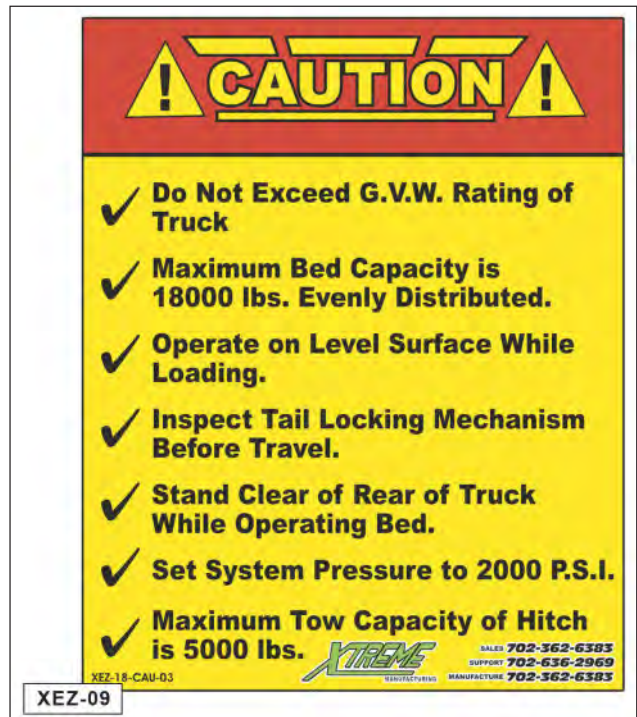



**24M Labels**

Table 3.  
24M Labels

Item	Qty.	Part No.	Description
1	2	XEZ-24-15C-03	Dove Tail Capacity
2	4	XEZ-24-24C-03	Truck Bed Capacity
3	4	XEZ-PP-03	Danger, Pinch Point
4	1	XEZ-CON-03	Controls
5	1	XEZ-24-CAU-03	Caution

**1. XEZ-24-15C-03**

**DOVE TAIL CAPACITY**  
Load to be evenly distributed  
**15,000 Lbs**  
Warning: Never exceed rated capacity

**XTREME** MANUFACTURING  
SALES 702-362-6383  
SUPPORT 702-636-2969  
MANUFACTURE 702-362-6383

XEZ-64 XEZ-24-15C-03

**2. XEZ-24-24C-03**

**TRUCK BED CAPACITY**  
Load to be evenly distributed  
**24,000 Lbs**  
Warning: Never exceed rated capacity

**XTREME** MANUFACTURING  
SALES 702-362-6383  
SUPPORT 702-636-2969  
MANUFACTURE 702-362-6383

XEZ-63 XEZ-24-24C-03

**3. XEZ-PP-03**

**DANGER**  
**PINCH POINT**  
Keep hands clear.

**XTREME** MANUFACTURING  
SALES 702-362-6383  
SUPPORT 702-636-2969  
MANUFACTURE 702-362-6383

XEZ-PP-03 XEZ-02

**4. XEZ-CON-03**

**XTREME** MANUFACTURING  
SALES 702-362-6383  
SUPPORT 702-636-2969  
MANUFACTURE 702-362-6383  
1611 W. Bonanza Rd.  
Las Vegas, NV 89106

**PUSH EZ-LOADER CONTROLS PULL**

**EXT. FLIP TAIL RET.**

**UP DOVE TAIL DOWN**

**IN WINCH OUT**

XEZ-CON-03 XEZ-08

**5. XEZ-24-CAU-03**

**CAUTION**

- ✓ Do Not Exceed G.V.W. Rating of Truck
- ✓ Maximum Bed Capacity is 24000 lbs. Evenly Distributed.
- ✓ Operate on Level Surface While Loading.
- ✓ Inspect Tail Locking Mechanism Before Travel.
- ✓ Stand Clear of Rear of Truck While Operating Bed.
- ✓ Set System Pressure to 2000 P.S.I.
- ✓ Maximum Tow Capacity of Hitch is 5000 lbs.

**XTREME** MANUFACTURING  
SALES 702-362-6383  
SUPPORT 702-636-2969  
MANUFACTURE 702-362-6383

XEZ-24-CAU-03 XEZ-65

## Standard Equipment

<b>Table 4. EZ Loader Standard Equipment</b>	
<b>Description</b>	<b>Feature</b>
Bulkhead	Bolted to frame, welded to bed
Ramp	Traction plate
Chain Boxes	
Tie Downs	Nylon strap Chain
Ramp	Knife edge
Positive Tail Lock	Non-hydraulic
Winch	Hydraulic, 9,000 lb (4082 kg) Capacity Hydraulic, 12,000 lb (5443 kg) Capacity Tension Kit included

## Optional Equipment

<b>Table 5. EZ Loader Optional Equipment</b>	
<b>Description</b>	<b>Feature</b>
Bed Options	1/4 or 1/16 inch polished aluminum diamond plate on bulkhead
Truck Options	Chain and binder rack (locking)
	Loading light bar (12 Volt)
	Stake racks
	Air seat (driver side only)
	Air brakes
	Alcoa aluminum wheels or chrome wheel covers
	Allison automatic transmission
	Locking differential
	Tilt and telescopic steering wheel
	Split bench seat
Special paint/pin striping	
Tool Box Options (W x D x H)	48 x 30 x 17 in (1219.2 x 762.0 x 431.8 mm)
	96 x 30 x 17 in (2438.4 x 762.0 x 431.8 mm)

## Specifications

<b>Table 6. Bed Specifications</b>			
<b>Model</b>	<b>12M</b>	<b>18M</b>	<b>24M</b>
<b>Description</b>	<b>Specification</b>		
<b>Capacities</b>			
Approximate Gross Vehicle Weight (GVW)	26,000 lb 11793 kg)	33,000 lb (14969 kg)	48,000 lb (21772 kg)
Bed Capacity	12,000 lb (5443 kg)	18,000 lb (8165 kg)	24,000 lb (10886 kg)
Dove Tail Lift Capacity	8,000 lb (3629 kg)	10,000 lb (4536 kg)	15,000 lb (6804 kg)
Tow Capacity	5,000 lb (2268 kg)	5,000 lb (2268 kg)	10,000 lb (4536 kg)
Hydraulic Pump P.T.O.	14 gpm (53 Lpm)	14 gpm (53 Lpm)	14 gpm (53 Lpm)
<b>Dimensions</b>			
Overall Bed (W x L)	8.50 x 20.67 ft (2.6 x 6.3 m)	8.50 x 25.25 ft (2.6 x 6.7 m)	8.50 x 25.25 ft (2.6 x 6.7 m)
Main Bed (W x L)	8.50 x 13.25 ft (2.6 x 4.0 m)	8.50 x 17.00 ft (2.6 x 5.2 m)	8.50 x 17.00 ft (2.6 x 5.2 m)
Dove Tail (W x L)	8.50 x 7.42 ft (2.6 x 2.3 m)	8.50 x 8.00 ft (2.6 x 2.4 m)	8.50 x 9.00 ft (2.6 x 2.7 m)
Flip Tail (W x L)	8.50 x 4.50 ft (2.6 x 1.4 m)	8.50 x 5.25 ft (2.6 x 1.6 m)	8.50 x 5.25 ft (2.6 x 1.6 m)
Bulkhead Height	58.00 in (1473.2 mm)	59.00 in (1498.6 mm)	70.00 in (1778.0 mm)
Cab To Axle (C.A.)	138.00 in (3505.2 mm)	185.00 in (4699.0 mm)	163.00 in (4140.2 mm)
Ramp Length	11.92 ft (3.6 m)	13.25 ft (4.0 m)	14.25 ft (4.3 m)
Bed Height (Ground)	38.50 in (977.9 mm)	42.00 in (1066.8 mm)	47.00 in (1193.8 mm)
Maximum Dock Height	60.00 in (1524.0 mm)	66.00 in (1676.4 mm)	75.00 in (1905.0 mm)
Ramp Degree/Percent	15/27%	15/27%	15/27%
Hitch Receiver Tube	2.00 in (50.8 mm)	2.00 in (50.8 mm)	2.00 in (50.8 mm)
Wood Thickness	1.00 in (25.4 mm)	1.00 in (25.4 mm)	1.50 in (38.1 mm)

Capacity rating for bed only, vehicle capacity rating dependent on final configuration of chassis, options installed, road regulation, and drivetrain specifications.

NOTE: Constant improvement and engineering progress make it necessary for us to reserve the right to make specification and equipment changes without notice.

## ⚠ WARNING



Perform a daily visual inspection and have necessary repairs made before operating the EZ Loader. Perform a daily pre-trip inspection in accordance with the Federal Motor

Carriers Safety Regulations (FMCSR 392.7). **DO NOT** perform the visual inspection with the truck engine running or hot. Contact with moving or heated parts can cause injury or death.

## ⚠ WARNING



Perform functional tests in an open area. Inspections and functional tests may require assistance. Keep the assistant visible and a safe distance from the truck to prevent injury or

death.

## Pre-Operation Inspection Checklist

Walk around the **ENTIRE** vehicle while visually performing the pre-operation inspection.

Check that “Do Not Operate” tags have not been placed on the vehicle or equipment.

Check that all Operator Manuals are in the vehicle and legible.

Check engine compartment for:

Damaged belts, hoses, and radiator blades.

Coolant reservoir level. Add radiator coolant, if necessary.

Engine oil level. Add engine oil, if necessary.

Electrical wires and connectors.

Check battery for:

Corrosion on terminals.

Cracked, melted, or damaged case.

Check all hydraulic hoses and hose connections for wear or leaks. Use a piece of cardboard.

Check hydraulic sight gauge for proper fluid level. The sight glass should show 3/4 full at all times. Add hydraulic fluid, if necessary.

Check all tires, rims, and wheels for:

Punctures, cracks, cuts, gouges, bulges, foreign objects, or any other damage to tires.

Correct pressure (pneumatic tires only).

Loose or missing lug nuts.

Bent flanges or any other damage to rims.

Check front and rear axles for leaks or any other damage.

Check that all labels and stickers are legible. Replace any damaged or illegible stickers.

Check mirrors for cracks, cleanliness, and proper adjustment.

Date: \_\_\_\_\_

Initials: \_\_\_\_\_



**⚠ WARNING**



A brief description of controls is provided as a convenience for the operator. These descriptions **DO NOT** provide complete operation instructions. Read and understand the entire manual to prevent equipment damage, injury, or death.

**Flip Tail Control**

The flip tail control lever activates a single hydraulic cylinder which extends and retracts the flip tail of the EZ Loader and releases or engages the locking mechanism.

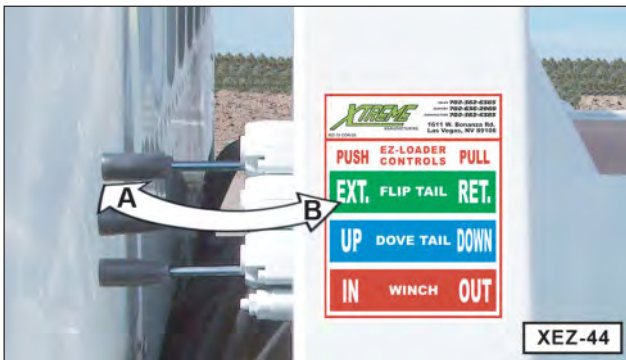

Figure 6-1. Flip Tail Control Lever. (A) Push To Extend Flip Tail. (B) Pull To Retract Flip Tail.

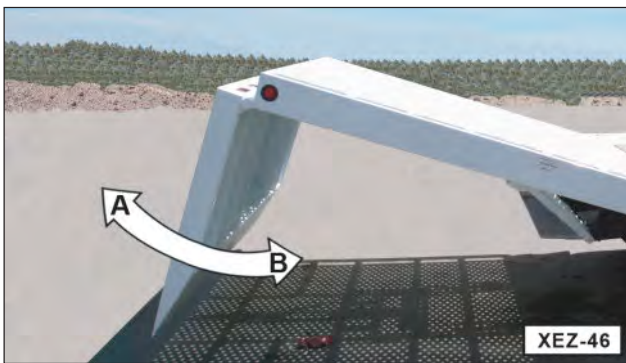

Figure 6-2. Flip Tail Extend (A) And Flip Tail Retract (B).

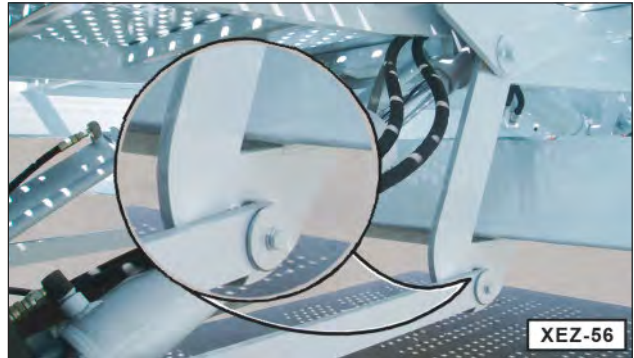

Figure 6-3. Flip Tail Control Lever Engages And Disengages Locking Mechanism.

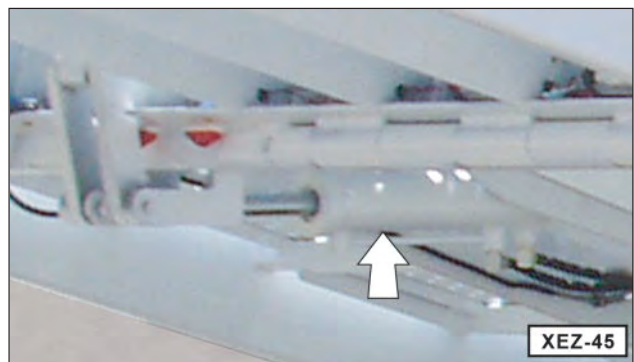

Figure 6-4. Flip Tail Hydraulic Cylinder.

**Dove Tail Control**

The dove tail control lever activates two (2) hydraulic cylinders which raise and lower the dove tail and, when the flip tail is extended, controls the ramp.

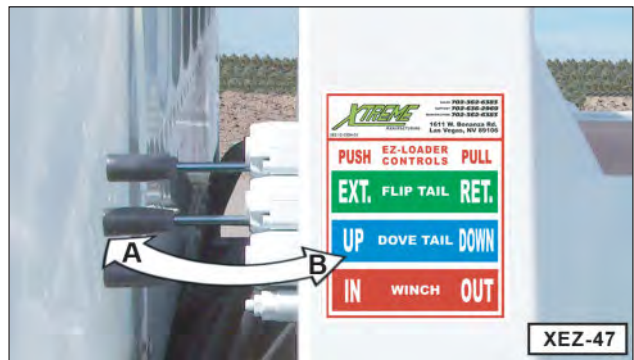

Figure 6-5. Dove Tail Control Lever. (A) Push To Raise Dove Tail Or Ramp Up. (B) Pull To Lower Dove Tail Or Ramp Down.

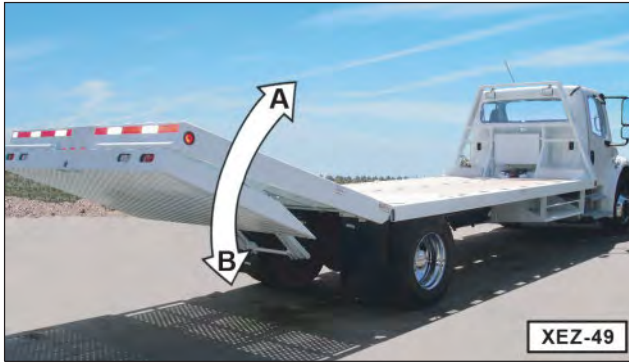

Figure 6-6. Dove Tail Raise (A) And Dove Tail Lower (B).

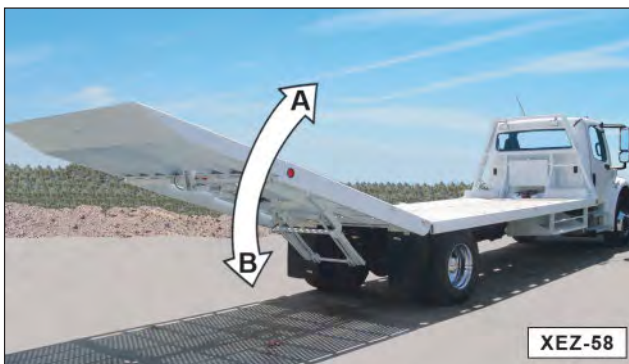

Figure 6-7. Raise Ramp (A) And Lower Ramp (B).



Figure 6-8. Dove Tail Hydraulic Cylinders.

## Winch Control

The winch control lever hydraulically activates the winch to spool (In) or unspool (Out) the wire rope.

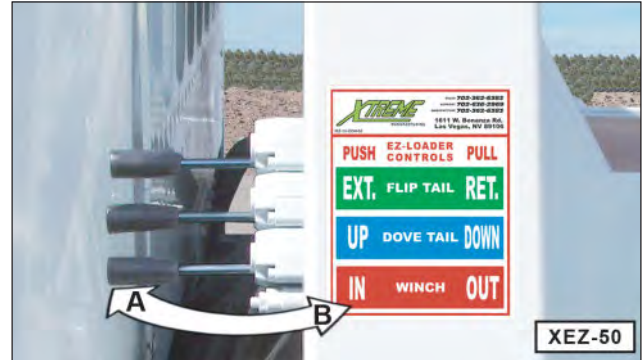

Figure 6-9. Winch Control Lever. (A) Push To Spool Wire Rope (In). (B) Pull To Unspool Wire Rope (Out).

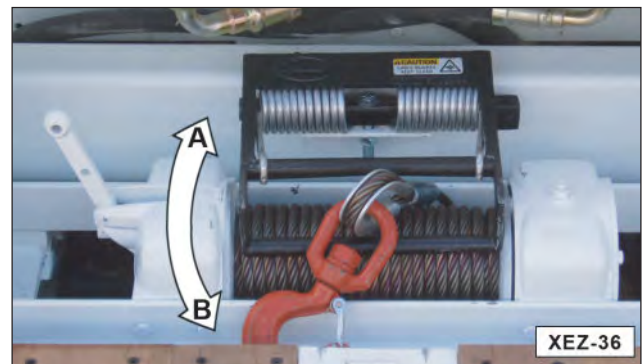

Figure 6-10. Winch Operation. (A) Spool (In). (B) Unspool (Out).

**NOTE:** The winch clutch must be engaged (A) for hydraulic winching operations and disengaged (B) for manual winching operations.

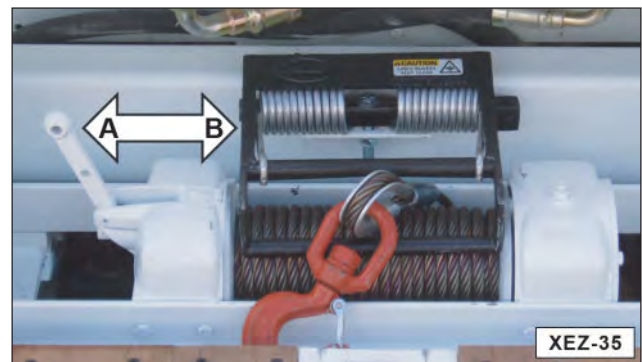

Figure 6-11. Winch Clutch. (A) Engaged For Hydraulic Operations. (B) Disengaged For Manual Operations.

**Power Take Off (PTO)**

**⚠ WARNING**

To prevent injury or death, follow these procedures when using the Power Take Off (PTO) to operate the EZ Loader.

- Park vehicle on a firm, level surface.
- Move transmission gear shift lever to NEUTRAL (N).



Make sure the transmission is in Neutral (N) before operating the Power Take Off (PTO). Operating the PTO with the transmission in gear can cause damage to the PTO or transmission and may cause the vehicle to move suddenly, resulting in injury or death.

- Set emergency brake to ON (engaged).



Always set the emergency brake to ON (engaged) before engaging the PTO. The vehicle can roll if the emergency brake is not ON

(engaged) resulting in injury or death.

- Chock the vehicle's wheels.



Always chock the vehicle's wheels before engaging the PTO. The vehicle can roll if the vehicle's wheels are not blocked resulting in

injury or death.

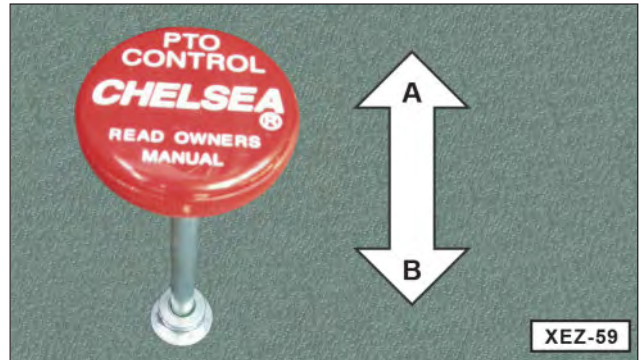

Figure 6-12. Power Take Off (PTO) Control. (A) Pull Up To Engage PTO. (B) Push Down To Disengage PTO.

Hydraulic power for the flip tail, dove tail, and winch is supplied through either a manual or electric Power Take Off (PTO).

If the PTO is manual, it is engaged and disengaged by a control mounted on the floor to the right of the vehicle operator's seat.

If the PTO is electronic, it is engaged and disengaged by a switch mounted on or below the vehicle dashboard.

**NOTE:** The PTO must be engaged to operate the flip tail, dove tail, and winch and it must be disengaged to drive the vehicle.



**Winch Operation**

**⚠ WARNING**



The winch safety and operating instructions are provided to enhance, NOT replace, the safety and operating instructions provided by the winch manufacturer. If you have any questions about safe winch operating procedures, refer to the manufacturer's instructions and other applicable industry guidelines and regulations.

Failure to follow safe winch operating procedures can result in equipment damage, injury, or death to the operator and others.

Only allow personnel trained by a qualified supervisor in safe winch operations to operate or maintain the winch.

The operator is responsible for exercising caution, using common sense, and being familiar with safe rigging techniques. Refer to applicable industry standards for rigging techniques, including ASME B30.9 for rigging information, American National Standards Institute, 1430 Broadway, New York, NY 10018.



Wear proper safety gear such as reflective clothing, hardhat, safety shoes, safety glasses and gloves. Always wear gloves when handling the wire rope.



**DO NOT** wear loose fitting clothing that can become entangled in the wire rope or other moving parts. Keep hands, clothing, etc. away from moving parts.



**DO NOT** place hands in the hook. Use a hook strap to spool and unspool the wire rope to keep hands away from pinch points. **DO NOT** try to guide the wire rope.

**⚠ WARNING**

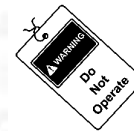

Inspect the winch for wear or damage before each shift. **DO NOT** operate a winch with a "DO NOT OPERATE" tag until it is repaired by authorized maintenance personnel. **DO NOT** operate a malfunctioning or damaged winch.



Operate the winch controls slowly and smoothly to avoid equipment damage, injury, or death. Ease slack out of the wire rope to avoid breaking it by applying extreme stress. **DO NOT** jerk the load.

Stand clear of the wire rope while under tension. Keep people a safe distance equal to 1-1/2 times the length of the wire rope.

Never winch when there are less than five (5) wraps of wire rope around the winch drum. Maintain at least five (5) tight wraps of wire rope on the drum at all times.

**DO NOT** exceed the maximum working limit of the winch, wire rope, and hardware when pulling a load.

**DO NOT** use the winch to lift, support, or move people.

Never use the winch's wire rope to tow another vehicle.

Never engage or disengage the winch clutch if winch is under load, wire rope is in tension, or wire rope drum is moving. Always make sure the clutch is fully engaged or disengaged.

**DO NOT** leave the clutch engaged when the winch is not in use. Never leave a load under tension with the winch unattended or not in use.



Avoid overheating the winch motor. Stop the winch at reasonable intervals to allow the winch motor to cool down.

**DO NOT** touch the winch with your bare hands after it has been operating for an extended period of time. The winch can become hot and cause a serious burn injury.

Secure the winch against unauthorized and unsafe usage.



**CAUTION**

Keep tension on wire rope to avoid slack that can result in twisting, overwrap, or other damage to wire rope.

The winch clutch allows the winch to be used hydraulically (A) or manually (B).

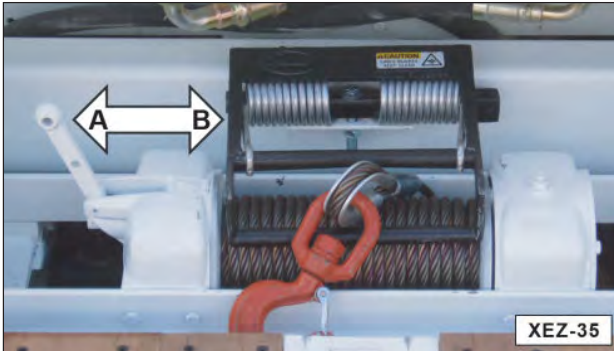

Figure 7-1. Engage Or Disengage Winch Clutch. (A) Engaged For Hydraulic Operations. (B) Disengaged For Manual Operations.

**NOTE:** The clutch must be engaged for hydraulic winching operations and disengaged for manual winching operations.

**WARNING**



**DO NOT** place hands in the hook. Use a hook strap to spool and unspool the wire rope to keep hands away from pinch points. **DO NOT** try to guide the wire rope.

To use the winch manually, disengage clutch by pushing the clutch lever toward the cable drum. Attach a hook strap to the hook and unspool the wire rope manually.

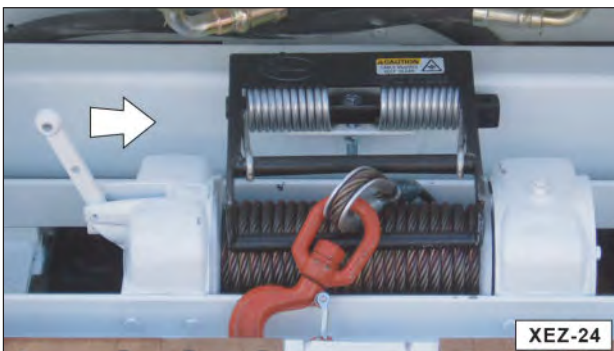

Figure 7-2. Winch Clutch Disengaged For Manual Operation.

To use the winch hydraulically, the clutch must be engaged.

1. To engage the clutch, push clutch lever out and away from the cable drum. Rotate drum until gears engage.

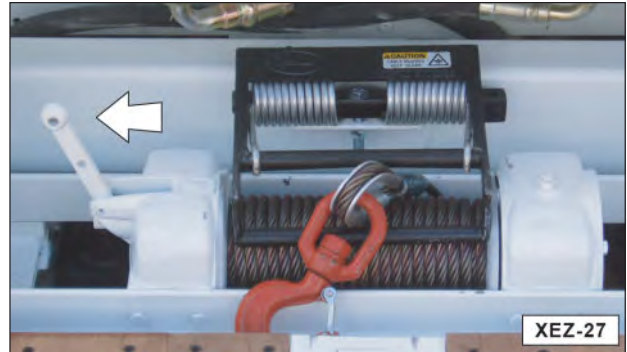

Figure 7-3. Winch Clutch Engaged For Hydraulic Operation.

2. Pull the winch control lever (bottom lever) to the OUT position to unspool wire rope.

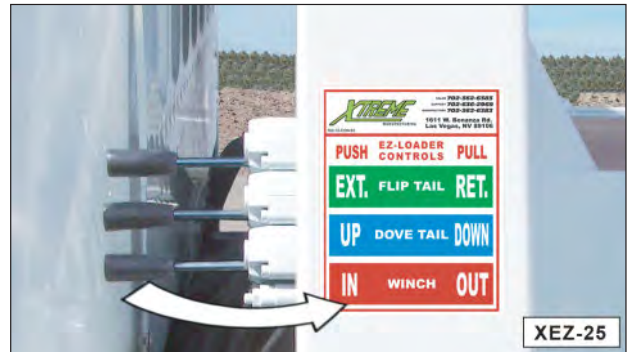

Figure 7-4. Pull Winch Control Lever (Bottom Lever) To The OUT Position.

**WARNING**



**DO NOT** place hands in the hook. Use a hook strap to spool and unspool the wire rope to keep hands away from pinch points. **DO NOT** try to guide the wire rope.

**CAUTION**

Keep tension on wire rope to avoid slack that can result in twisting, overwrap, or other damage to wire rope.

- Unspool enough wire rope to reach the load and apply safe rigging techniques, according to industry standards.

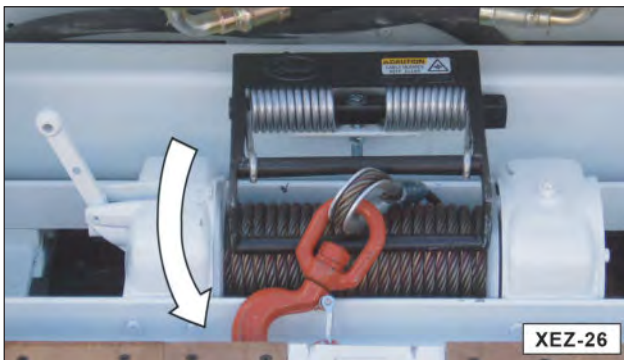

Figure 7-5. Unspool Wire Rope.

- After the load is safely rigged, push the winch control lever (bottom lever) to the IN position to spool wire rope.

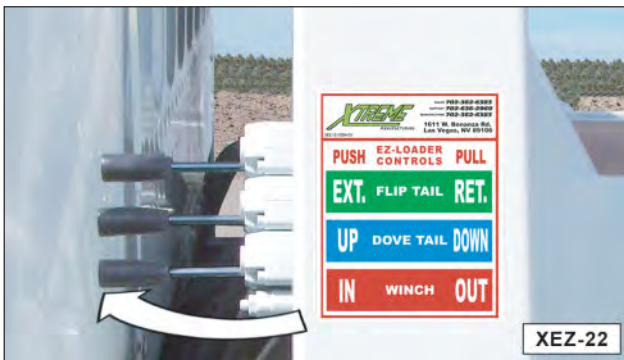

Figure 7-6. Push Winch Control Lever (Bottom Lever) To The IN Position.

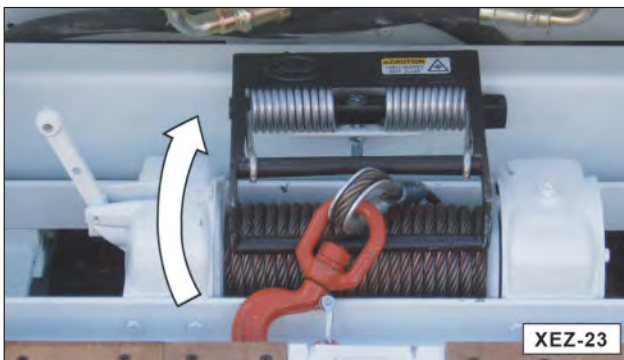

Figure 7-7. Spool (In) Wire Rope.

## Extend Ramp

- Park EZ Loader on a firm, level surface.
- Set parking brake.

### WARNING



Chock tires to stop vehicle from rolling. Failure to chock tires or improper use of chocks can cause the vehicle to roll, resulting

in injury or death.

- Chock wheels.



Figure 7-8. Chock Wheels.

- Place transmission in neutral.
- Engage the power take off (PTO).



Figure 7-9. Engage Power Take Off.

**NOTE:** Always engage the clutch, pull the PTO lever all the way up to engage the PTO, and then release the clutch.



6. Extend the ramp.
  - a. Push the dove tail control lever (middle lever) to the UP position.



Figure 7-10. Push Dove Tail Control Lever To The UP Position.

**NOTE:** This raises the dove tail up and provides clearance to extend the flip tail.



Figure 7-11. Raise Dove Tail Up.

- b. Push the flip tail control lever (top lever) to the EXTEND position.

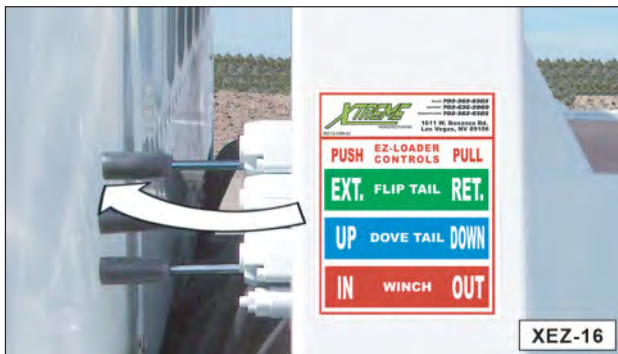

Figure 7-12. Push Flip Tail Control Lever To The EXTEND Position.

**NOTE:** This releases the flip tail from the locking mechanism and extends the flip tail.

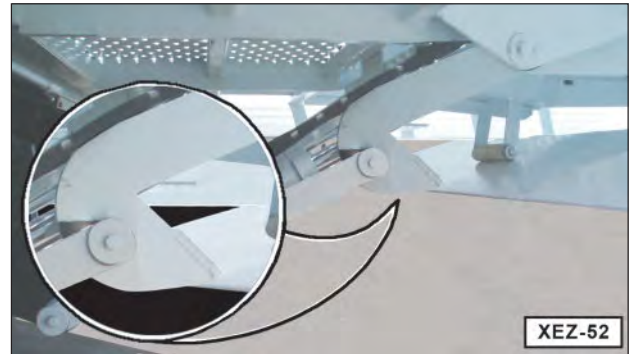

Figure 7-13. Make Sure Flip Tail Releases From Locking Mechanism.

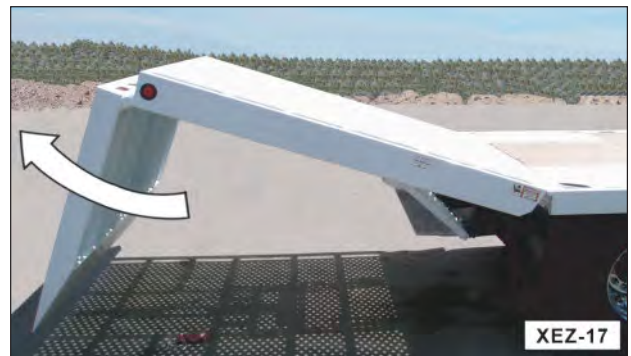

Figure 7-14. Extend Flip Tail Up.

- c. Continue to extend the flip tail until the ramp (dove tail and flip tail) reaches full extension.



Figure 7-15. Make Sure The Ramp (Dove And Flip Tail) Is Fully Extended.

- d. Pull the dove tail control lever (middle lever) to the DOWN position to lower the ramp to the ground.

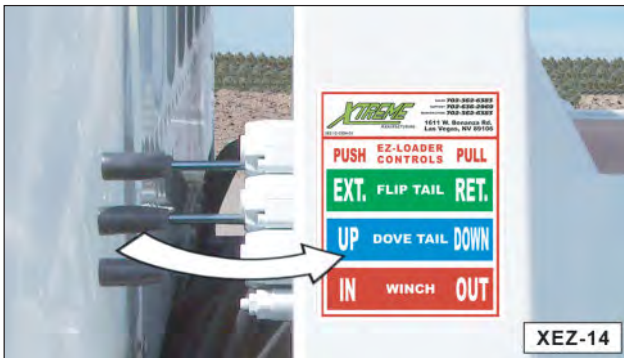

Figure 7-16. Pull Dove Tail Control Lever To The DOWN Position To Lower Ramp.



Figure 7-17. Lower Ramp.

- e. Make sure ramp is firmly grounded.



Figure 7-18. Make Sure Ramp Is Firmly Grounded.

## Loading Operation

### ⚠ WARNING

Plan ahead. Study the load and loading area.

Make sure the loading area is a firm, flat surface without overhead obstructions and powerlines.

Keep the ramp travel area behind the truck clear to raise, lower, open, and close the ramp.

Keep the area around the truck where a load might fall clear before and during loading, unloading, and operating the EZ Loader.

Keep the load path clear of bystanders. **DO NOT** allow anyone near, behind, or standing on a load being loaded or unloaded.

1. Extend the ramp. (Refer to Extend Ramp section in this manual.)
2. Align the load with the truck bed. **DO NOT** exceed a 3° angle from the centerline of the truck.
3. Pull the winch control lever (bottom lever) to the OUT position to unspool the wire rope.

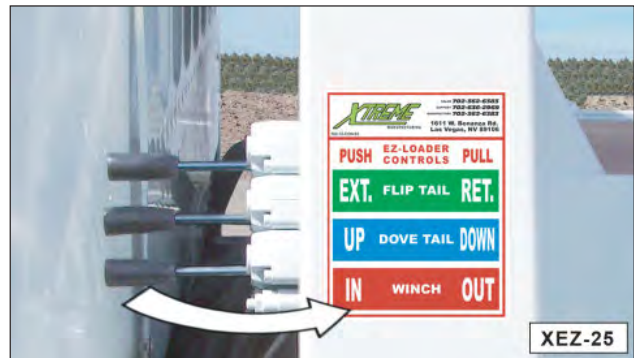

Figure 7-19. Pull Winch Control Lever (Bottom Lever) To The OUT Position.

### ⚠ WARNING

The operator is responsible for exercising caution, using common sense, and being familiar with safe rigging techniques. Refer to applicable industry standards for rigging techniques, including ASME B30.9 for rigging information, American National Standards Institute, 1430 Broadway, New York, NY 10018.

Make sure the load is properly seated in the hook to secure the load and prevent damage to the hook.



4. Rig the load using industry standards.

**⚠ WARNING**

Remain alert. Always pay attention and keep an unobstructed view while pulling a load.

5. Push the winch control lever (bottom lever) to the IN position to ease slack out of the wire rope before pulling a load.

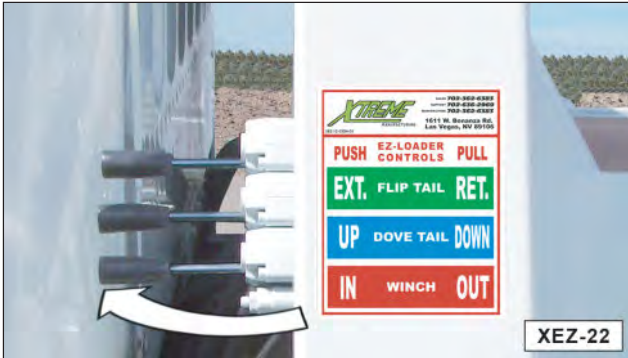

Figure 7-20. Push Winch Control Lever (Bottom Lever) To The IN Position.

**⚠ WARNING**

The load can affect the driving and handling characteristics of the truck. Follow industry standards to safely and securely load the truck. Evenly distribute the load weight on the truck bed and make sure the load height is within legal requirements.

**DO NOT** exceed the manufacturer’s maximum rated capacity on the truck bed, dove tail, ramp, or axles. Overloading can result in equipment damage, injury, or death.

Capacity rating for bed only, vehicle capacity rating dependent on final configuration of chassis, options installed, road regulation, and drivetrain specifications.

6. Pull the load onto the EZ loader and place the load for safe transport.



Figure 7-21. Place Load On EZ Loader.  
For information call (800) 497-1704

**⚠ WARNING**



Securely fasten all vehicles, crates, machinery, etc. for transport. Apply chocks to wheels of a vehicle or rolling equipment. Make sure no loose objects or equipment remain on the truck bed.

Use binding equipment rated for the load and attach binding equipment to pull from opposite directions, such as from the four corners.

**DO NOT** damage fragile or vital components on the load.

7. Secure the load according to industry standards.



Figure 7-22. Secure Load.

8. Secure winch, tools, and tool boxes for transport.
9. Retract the ramp. (Refer to Retract Ramp section in this manual.)

## Unloading Operation

### ⚠ WARNING

Plan ahead. Study the load and unloading area.

Make sure the unloading area is a firm, flat surface without overhead obstructions and powerlines.

Keep the ramp travel area behind the truck clear to raise, lower, open, and close the ramp.

Keep the area around the truck where a load might fall clear before and during loading, unloading, and operating the EZ Loader.

Keep the load path clear of bystanders. **DO NOT** allow anyone near, behind, or standing on a load being loaded or unloaded.

1. Extend the ramp. (Refer to Extend Ramp section in this manual.)

### ⚠ WARNING

The operator is responsible for exercising caution, using common sense, and being familiar with safe rigging techniques. Refer to applicable industry standards for rigging techniques, including ASME B30.9 for rigging information, American National Standards Institute, 1430 Broadway, New York, NY 10018.

Make sure the load is properly seated in the hook to secure the load and prevent damage to the hook.

2. Rig the load using industry standards.
3. Remove load tie-downs and chocks.

4. Pull the winch control lever (bottom lever) to the OUT position to unspool the wire rope and load.

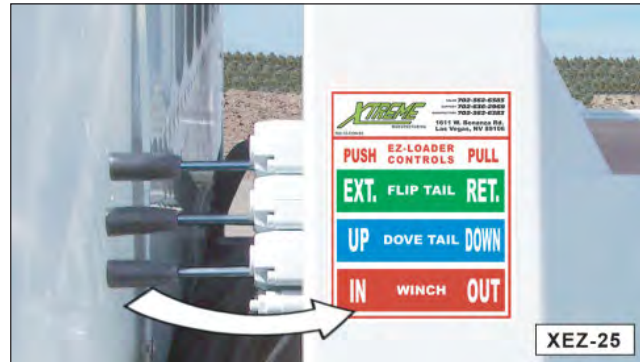

Figure 7-23. Pull Winch Control Lever (Bottom Lever) To The OUT Position.

5. Remove load from EZ Loader.
6. Push the winch control lever (bottom lever) to the IN position to spool the wire rope.

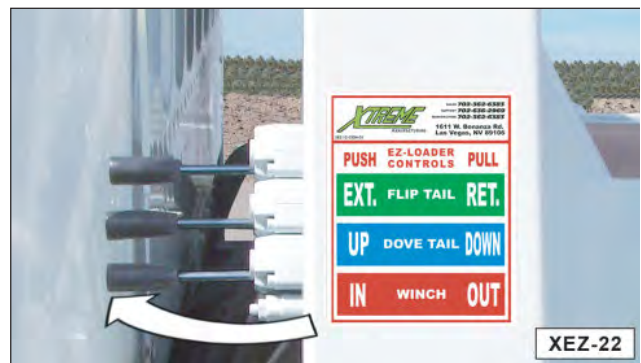

Figure 7-24. Push Winch Control Lever (Bottom Lever) To The IN Position.

7. Retract the ramp. (Refer to Retract Ramp section in this manual.)

## Retract Ramp

1. Retract the ramp.
  - a. Push the dove tail control lever (middle lever) to the UP position.

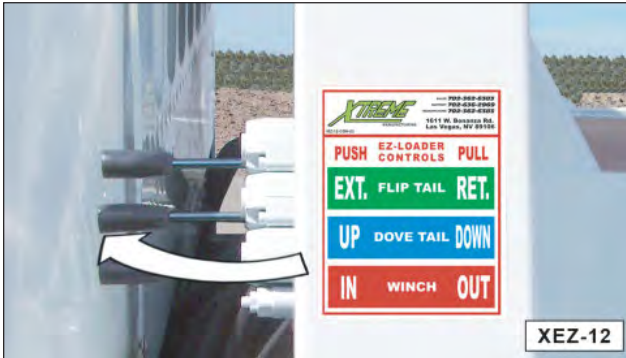

Figure 7-25. Push Dove Tail Control Lever To The UP Position.

**NOTE:** This raises the ramp up and provides clearance to retract the flip tail.



Figure 7-26. Raise Ramp Up.

- b. Pull the flip tail lever (top Lever) to the RETRACT position.

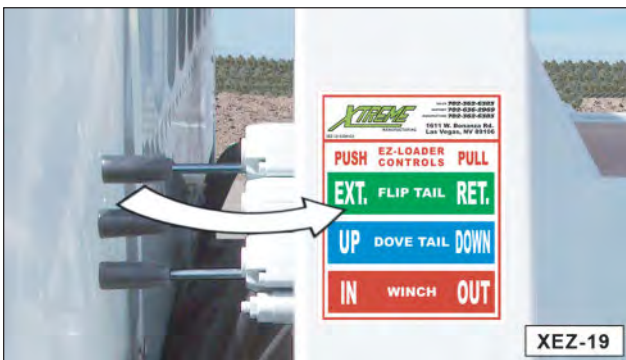

Figure 7-27. Pull Flip Tail Control Lever To The RETRACT Position.

**NOTE:** This retracts the flip tail and engages the locking mechanism.



Figure 7-28. Retract Flip Tail.

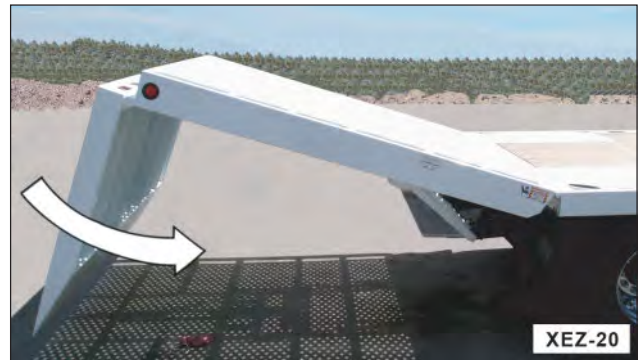

Figure 7-29. Retract Flip Tail.

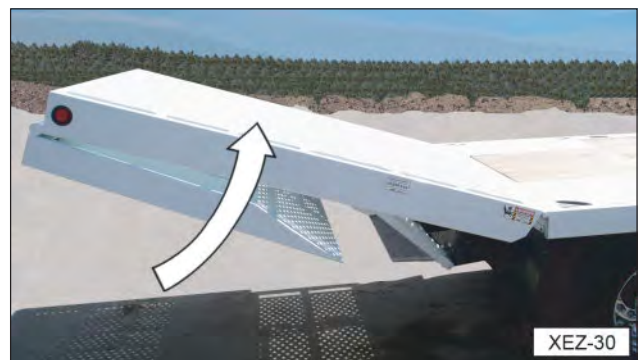

Figure 7-30. Retract Flip Tail Until It Folds Completely Under The Dove Tail.





Figure 7-31. Make Sure Flip Tail Engages Locking Mechanism.

- c. Pull dove tail lever (middle lever) to the DOWN position to lower dove tail.

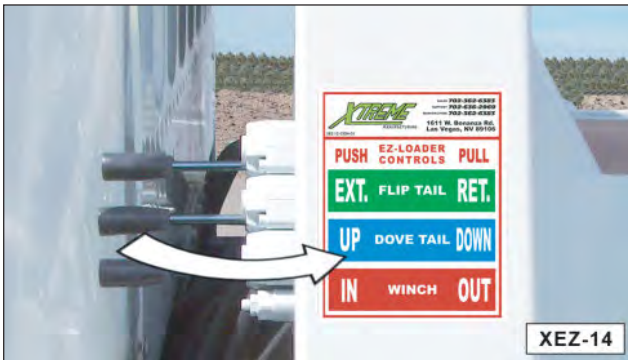

Figure 7-32. Pull Dove Tail Control Lever To The DOWN Position.



Figure 7-33. Lower Dove Tail.

- 2. Remove and secure vehicle wheel chocks.



Figure 7-34. Chock Wheels.

- 3. Disengage the power take off (PTO).



Figure 7-35. Disengage Power Take Off.

**NOTE:** Always engage the clutch, push the PTO lever all the way down to disengage the PTO, and then release the clutch.

- 4. Release parking brake.

**CAUTION**

**DO NOT** drive the EZ Loader unless the flip tail is secured in the stored position by the locking mechanism. Failure to make sure the flip tail is secured in the storage position can result in equipment damage.



## ⚠ WARNING

Follow the manufacturer's instructions for proper maintenance to make sure the vehicle continues to meet manufacturer's specifications.

**DO NOT** operate the vehicle and attachments if they require repairs or "Do Not Operate" tags have been placed on them.

Make sure basic maintenance is completed and service problems are corrected.

Injury or death can result from operating a vehicle before all repairs have been made and all proper maintenance is completed.



Consult Material Safety Data Sheets (MSDS) for chemical hazards and first aid instructions. MSDS should be available from

the manufacturer or supplier of the fluid.

## Weekly Maintenance

## ⚠ CAUTION



Pressurized water can spray debris, hot fluids, or chemicals on personnel in the vicinity and can result in personal injury. Wear

protective clothing, safety shoes, and a face shield or safety glass when using pressurized water for cleaning. **DO NOT** exceed a maximum of 40 psi (275 kPa) water pressure for cleaning purposes. Always wear eye protection for cleaning the cooling system.

1. Use a high pressure washer to clean fluids and other debris from the dove tail and flip tail.
2. Check attachment hardware (nuts and bolts) on the dove tail and flip tail linkage for tightness. Vibration and stress can loosen properly torqued bolts.
3. Make sure all hydraulic fittings are securely attached.
4. Lubricate all hinges and pivot points with penetrating oil or spray.
5. Check the hydraulic filter for contamination. When the hydraulic filter gauge is green this indicates the filter is clean. When the hydraulic filter gauge is yellow, this indicates the filter needs to be replaced.

For information call (800) 497-1704

## Semi-Annual Maintenance

Replace the hydraulic oil filter and oil every six (6) months or sooner if the hydraulic filter indicator is yellow, indicating the filter is dirty.

## Replacing Oil and Filter

## ⚠ WARNING

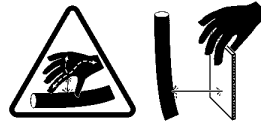

Check hydraulic oil lines, tubes, and hoses carefully. **DO NOT** use your bare hand to check for leaks. Always use a board or

cardboard when checking for a hydraulic leak. Escaping hydraulic fluid under pressure, even a pinhole size leak, can penetrate body tissue, causing injury or death. If hydraulic oil is injected into your skin, a doctor familiar with this type of injury must treat it immediately.

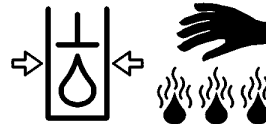

Personal injury can result from hydraulic oil pressure or hot oil. **DO NOT** remove a hydraulic tank filler cap unless it is cool enough to

touch with bare hands. Remove the hydraulic tank filler cap slowly to relieve pressure. Relieve all pressure in a hydraulic system before any caps, lines, fittings, or related items are disconnected or removed.

## CAUTION

Keep the hydraulic system clean. Service the hydraulic system with extreme care. Failure to change the hydraulic oil and filter regularly can void the warranty of some components. Small amounts of dirt or foreign material can cause extensive damage to pumps, motors, and valves. **DO NOT** use brake fluid in the hydraulic system.

1. Before opening hydraulic oil reservoir, wipe away all dirt, grease, and grime around filter cap. Make sure all containers, funnels, and pouring spouts to be used are clean.
2. Remove the oil filter. Drain oil into an appropriate container and dispose of properly.
3. Install a 51759 WIX Oil Filter according to filter installation instructions.

- 4. Add up to four (4) quarts of AW46 or AW68 CITGO Hydraulic Oil to the hydraulic oil reservoir. Fill the reservoir to the full line on the sight glass.



Figure 8-1. Sight Glass On Hydraulic Oil reservoir.

- 5. Test all ramp functions.
- 6. Check for hydraulic leaks.



Figure 8-2. "Do Not Operate" Tags.





24921-000 5/2020

**(702) 636-2969**  
**(800) 497-1704**

**1415 W. Bonanza Rd. Las Vegas, NV 89106**  
**[www.XtremeManufacturing.com](http://www.XtremeManufacturing.com)**